

Air Curtain Mounting Bracket

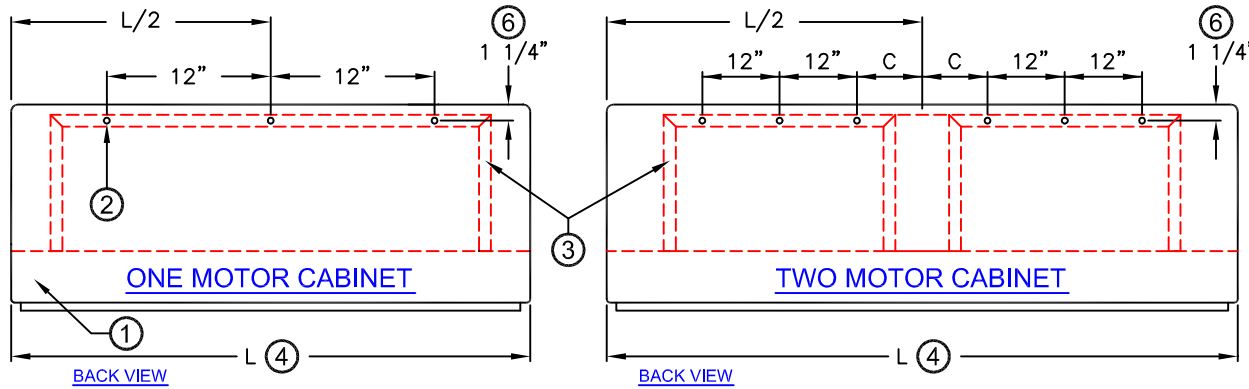

Air Curtain Cabinet

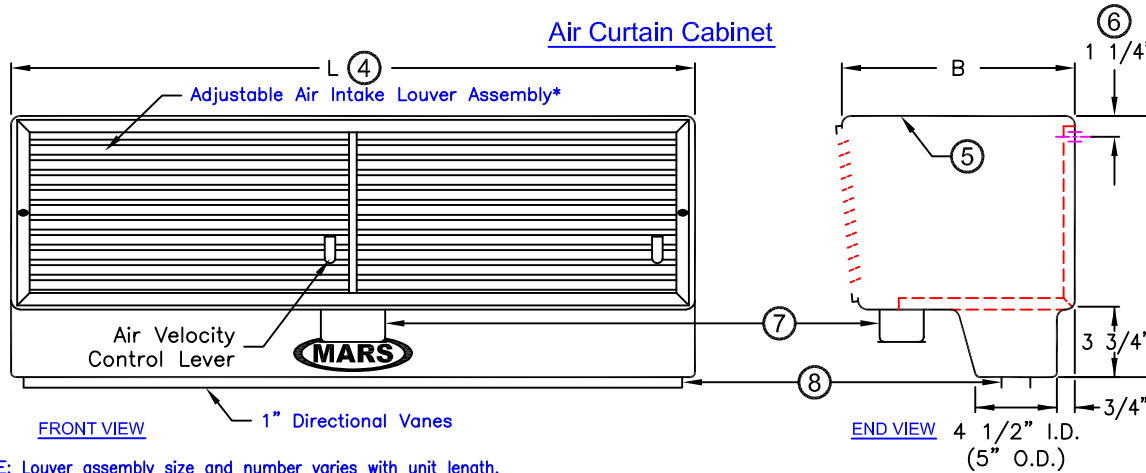

NOTES:

- ① This product is designed to comply with the National Electric Code (NEC) and is U.L. Listed and CSA Certified.
- ② 7/16" mounting holes. (3) provided on one motor models, (6) provided on two motor models.
- ③ Cabinets contain an internal steel bracket with sufficient strength to provide cabinet rigidity and fastening to wall.
- ④ Model number indicates length of unit in inches, which is denoted as "L". Actual length may vary up to 1 1/4" over model number.
- ⑤ All units have a self contained one piece molded white high density polyethylene cabinet. Cabinets feature a self-extinguishing characteristic and are resistant to high humidity, chemical and climate exposures.
- ⑥ Wall mounting hole location. Model number 96CH-2 and all 1 HP models are 3 3/4".
- ⑦ One watertight junction box per motor mounted on bottom center of each motor/fan assembly. Specify for alternate locations.
- ⑧ Units is to be installed such that air flow is unobstructed. Air discharge nozzle containing adjustable air directional vanes with 40° sweep front to back.
- ⑨ Optional motor control panel. Overloads are factory preset. Panels are to be shipped loose for remote mount.
- ⑩ Circuit protection as per N.E.C. by others.
- ⑪ Microswitch is field installed and is to be wired to the control panel. Switch to be mounted such that air curtain turns on as door starts to open.



*NOTE: Louver assembly size and number varies with unit length.

MODEL NUMBER ④	NUMBER OF MOTORS	HEIGHT A	DEPTH B	MOUNTING HOLE SPACING C
36CH	1	14 3/4"	12 3/4"	-
38CH	1	14 3/4"	12 3/4"	-
42CH	1	14 3/4"	12 3/4"	-
48CH	1	14 3/4"	12 3/4"	-
60CH-2	2	14 3/4"	12 3/4"	4 3/4"
72CH-2	2	14 3/4"	12 3/4"	5"
96CH-2	2	18"	15"	12"
42CHS	1	18"	15"	-
48CHS	1	18"	15"	-
60CHS	1	18"	15"	-
96CHS-2	2	18"	15"	10"

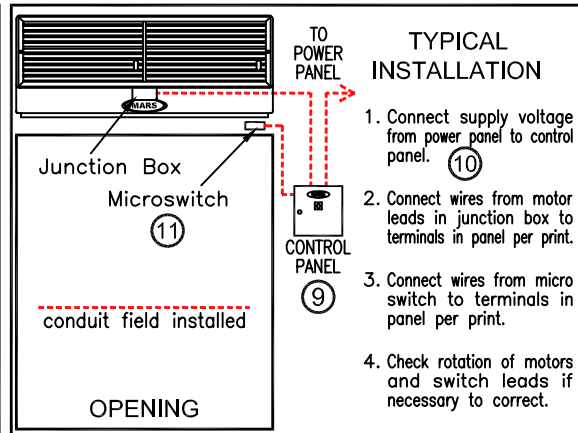

PROJECT	MODEL NO.
LOCATION	DRAWING NO.
ARCHITECT	DATE
ENGINEER	SHEET OF
	DRAWN BY
	CHECKED BY
	PROJECT NO.

14716 S. BROADWAY • GARDENA, CA 90248
 Phone: 310-532-1555 • 800-421-1266 • Fax: 310-324-3030
 WEB SITE: www.marsair.com • E-MAIL: marsinfo@marsair.com

CH - CHS COMMERCIAL HIGH VELOCITY UNHEATED MODELS

MARK	CH/CHS MODEL NUMBER	NO. REQ'D	LENGTH	WEIGHT (LBS)	HP 1750 RPM	VOLTS & PHASE	MOTOR FAN DATA				Max FPM at Nozzle	Max CFM at Nozzle	dBA Measured 10 ft. from Nozzle	REMARKS
							FLA (AMPACITY) SINGLE PHASE		FLA (AMPACITY) THREE PHASE					
							115V	208V 240V	208V 240V	460V				
	36CH		3'	50	1/2		5.1 (6.4)	2.5 (3.2)	1.8 (2.3)	0.8 (1.0)	3400	2550	63	
	38CH		3' 2"	52	1/2		5.1 (6.4)	2.5 (3.2)	1.8 (2.3)	0.8 (1.0)	3225	2550	63	
	42CH		3' 6"	55	1/2		5.1 (6.4)	2.5 (3.2)	1.8 (2.3)	0.8 (1.0)	2925	2550	63	
	48CH		4'	60	1/2		5.1 (6.4)	2.5 (3.2)	1.8 (2.3)	0.8 (1.0)	2550	2550	63	
	60CH-2		5'	95	Two 1/2		10.2 (12.8)	5.1 (6.4)	3.6 (4.2)	1.6 (2.0)	4080	5100	65	
	72CH-2		6'	105	Two 1/2		10.2 (12.8)	5.1 (6.4)	3.6 (4.2)	1.6 (2.0)	3400	5100	65	
	96CH-2		8'	130	Two 1/2		10.2 (12.8)	5.1 (6.4)	3.6 (4.2)	1.6 (2.0)	2550	5100	65	
	42CHS		3' 6"	80	1		13.0 (16.3)	6.8 (8.5)	3.3 (4.1)	1.6 (2.0)	4600	4000	69	
	48CHS		4'	85	1		13.0 (16.3)	6.8 (8.5)	3.3 (4.1)	1.6 (2.0)	4000	4000	69	
	60CHS		5'	90	1		13.0 (16.3)	6.8 (8.5)	3.3 (4.1)	1.6 (2.0)	3200	4000	69	
	96CHS-2		8'	160	Two 1		*	13.6 (17.0)	6.6 (8.2)	3.2 (4.0)	4000	8000	72	

EQUIPMENT SPECIFICATIONS – Standard Features

GENERAL

Air curtain shall be a Mars® Air Doors brand air curtain: Type "CH" or "CHS" Commercial High Velocity Unheated Models.

APPROVALS

Air curtain shall be Underwriters Laboratories Listed (specify if for outdoor), Canadian Standard Association Certified and meet the requirements of the National Electric Code.

CABINET

Cabinet shall be a self contained one piece molded white high density polyethylene material. Cabinets shall feature self-extinguishing characteristics and be resistant to high humidity and climatic exposures. Cabinets to contain an internal steel bracket with sufficient strength to provide cabinet rigidity and fastening to the wall. Cabinet to have mechanically field adjustable variable air intake louver assembly capable of reducing outlet air velocity up to 60% with louvers in totally closed position. Discharge air outlet nozzle shall be wedged shaped containing adjustable air directional vanes with a 40° sweep front to back. Motor/Fan assembly to be easily accessible for maintenance.

MOTORS AND BLOWER WHEELS

Motor(s) shall be totally enclosed air over (TEAO) type suitable for continuous heavy duty, all angle operation. Construction shall include sealed lifetime pre-lubricated ball bearings, resilient mounted and protected by an automatic reset thermal overload switch. Motor(s) to have a cord which connects to a removable watertight fitting on the junction box(s) for fast and easy removal of motor/fan assembly for inspection and cleaning. Quick disconnect motor plugs are used for 1/2 HP, 1 phase units. Motor(s) to have double extended shaft and direct drive, double inlet, dynamically balanced forward curved squirrel cage blower wheels.

ELECTRICAL WIRING

Each motor to have a watertight junction box mounted on bottom center of each motor/fan assembly. Specify for alternate locations.

GUARANTEE

Shall be five years on all parts.

*** - NOT RECOMMENDED, 32 FLA REQUIRED. CONSULT FACTORY.**

An equipment specification can be prepared by combining the standard features with the checked boxes below indicating the selection of the optional features.

OPTIONAL FEATURES

When checked below, the air curtain will be supplied with the following special features.

- Explosion proof motors
- Two speed motor (Available in single phase only)
- Door microswitch(s) (20 amp) for automatic on/off control. Turns air curtain on when door is opened and off when door is closed. Field installed.
Note: All 3 Phase Motors or Single Phase Combined Motors greater than 1 Hp or over 250Vac or greater than 20 Amps require a motor control panel whenever a door microswitch is used to start and stop the air curtain. A door microswitch may be used to directly control one 1 HP or one or two 1/2 HP, single phase motors without the need for a motor control panel. (As long as it does not exceed 20 AMPS or 250 VAC)
- Magnetic Reed Switch(s) (.25 amp 24V) for automatic on/off control. Turns air curtain on when door is opened and off when door is closed. Field installed.
Note: All 3 Phase Motors & Single phase motors greater than 1 Hp require a motor control panel whenever a Reed Switch is used to start/stop the air curtain. A Reed Switch can directly control (1) 1 HP or (2) 1/2 HP. Single phase Motors without the need of a control panel BUT requires a controller, field wired in the junction box.
- Wall mounted control panel Factory mounted control panel on air curtain
 Indicate the total number of motors to be powered through panel
 1 2 3 4
- Washable aluminum air filter
 - In lieu of adjustable inlet air louver
 - In conjunction with adjustable inlet air louver

MADE WITH PRIDE IN THE U.S.A.