

ZEPHYR AMBIENT SYSTEM

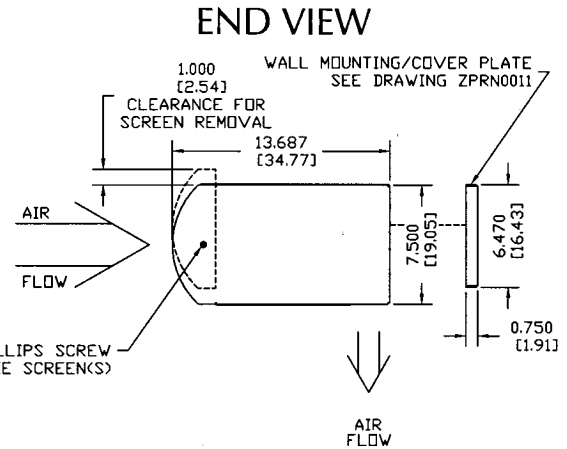
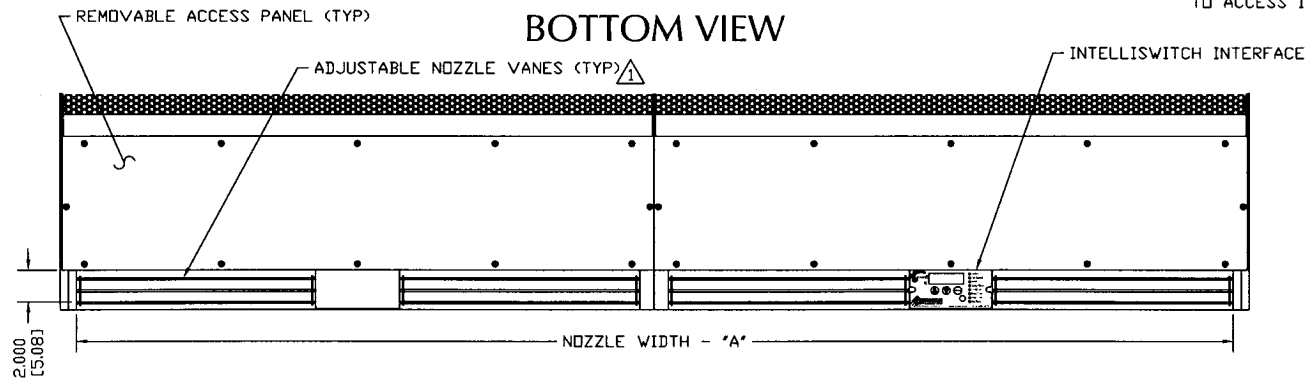
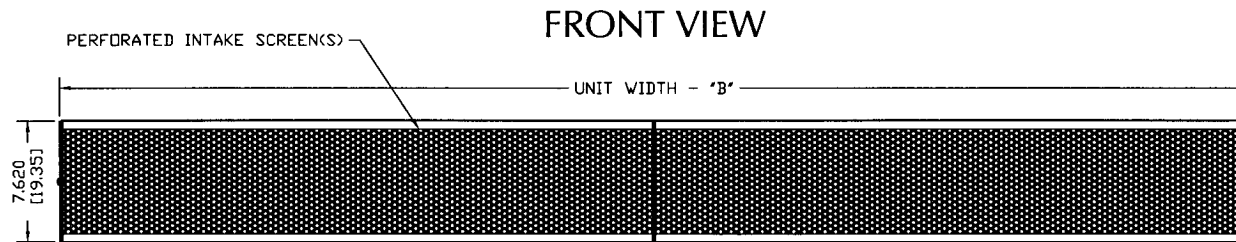
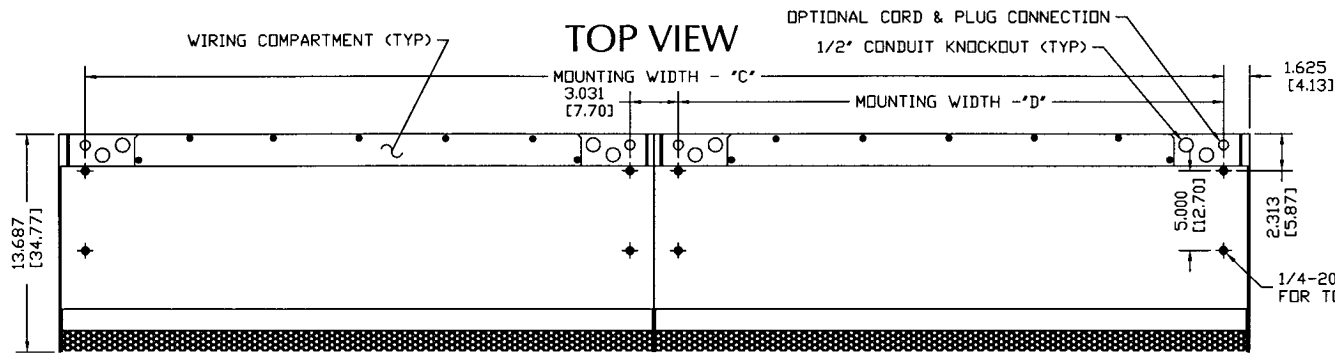

NOTES:

- ① AIR CURTAIN MUST BE INSTALLED SO AIR STREAM IS NOT OBSTRUCTED WHEN DEFLECTED 20° TO EITHER SIDE OF ϕ .
- ② ELECTRICAL CONNECTIONS TO BE FLEXIBLE.
- ③ FIELD VERIFY DIMENSIONS.
- ④ ANCHORS TO SUPPORTING STRUCTURE BY OTHERS.
- ⑤ ADEQUACY OF SUPPORTING STRUCTURE IS TO BE VERIFIED BY A PROFESSIONAL STRUCTURAL ENGINEER.
- ⑥ LETTER 'A' IN MODEL NUMBER DESIGNATES AMBIENT UNIT.
- ⑦ DIMENSIONS IN INCHES (CENTIMETERS).

MODEL ⑦	NOZZLE WIDTH "A"	UNIT WIDTH "B"	MOUNTING WIDTH "C"	MOUNTING WIDTH "D"
ZPR1030A	28.00 [71.12]	30.00 [76.20]	26.75 [67.95]	-
ZPR1036A	35.25 [89.54]	37.25 [94.62]	34.00 [86.36]	-
ZPR1042A	41.25 [104.78]	43.25 [109.86]	40.00 [101.60]	-
ZPR1048A	47.25 [120.02]	49.25 [125.10]	46.00 [116.84]	-
ZPR1060A	59.00 [149.86]	61.00 [154.94]	57.75 [146.69]	-
ZPR1072A	72.25 [183.59]	74.25 [188.60]	71.00 [180.34]	-
ZPR2084A	84.25 [213.00]	86.25 [219.08]	83.00 [210.82]	40.00 [101.60]
ZPR2096A	96.25 [244.48]	98.25 [249.56]	95.00 [241.30]	46.00 [116.84]
ZPR2120A	119.75 [304.17]	121.75 [309.25]	118.50 [300.99]	57.75 [146.69]

PROJECT		
LOCATION		
ARCHITECT		
ENGINEER		
DWG. NO.	ZPRR0033	TITLE: BERNER
DATE	23FEB04	MODEL ZEPHYR AIR CURTAIN
BY	A. Johnston	AMBIENT SYSTEM
REPLACES	10MAR03	
BY	D. Johnson	BERNER INTERNATIONAL CORP. NEW CASTLE, PA.