

**READ AND SAVE
THESE INSTRUCTIONS**



No.: II-260
Date: October, 2007

DIPLOMAT

AIR DOOR
Made in the USA

MARK

AIR DOOR
Made in the USA

Installation & Maintenance Instructions



WARNING: TO REDUCE THE RISK OF FIRE, ELECTRIC SHOCK, OR INJURY TO PERSONS, OBSERVE THE FOLLOWING:

- A. Use this unit only in the manner intended by the manufacturer. If you have any questions, contact the manufacturer.
- B. Before servicing or cleaning unit, switch power off at service panel and lock the service disconnecting means to prevent power from being switched on accidentally. When the service disconnecting means cannot be locked, securely fasten a prominent warning device, such as a tag, to the service panel.
- C. Installation work and electrical wiring must be done by qualified person(s) in accordance with all applicable codes and standards, including fire-rated construction.
- D. Sufficient air is needed for proper combustion and exhausting of gases through the flue (chimney) of fuel burning equipment to prevent back drafting. Follow the heating equipment manufacturer's guideline and safety standards such as those published by the National Fire Protection Association (NFPA), and the American Society for Heating, Refrigeration and Air Conditioning Engineers (ASHRAE), and local code authorities.
- E. When cutting or drilling into wall or ceiling, do not damage electrical wiring and other hidden utilities.

UNCRATING

Carefully examine the carton(s) for damage before opening. If the carton is damaged, immediately notify the shipping company. Open the carton and remove all protective packing. Remove the unit by lifting vertically. Place the unit upside down on end supports to avoid damage to the electrical junction box. If the unit will be wall mounted, remove and save the two (2) locking screws from the back corners and detach the wall mounting plate. **See Figure 1.**

The DIPLOMAT/MARK II air door is designed to be an effective barrier against cold drafts in the winter and hot humid air in the summer. To achieve optimum protection, the unit should be mounted on the inside of the building, flush to the wall (do not obstruct the nozzle or air stream) and as close to the top of the door opening as possible. **See Figure 2.**

BERNER INTERNATIONAL CORPORATION

New Castle, Pennsylvania

724-658-3551 • 1-800-245-4455 • www.berner.com • airdoors@berner.com

INDOOR INSTALLATION - WALL MOUNTING

Unit should be mounted no higher than 10' above the floor. For maximum efficiency, the unit should be mounted no higher than 8'.

1. Install the DIPLOMAT/MARK II Series Air Door so that nothing interferes with the curtain of air when it is deflected 20° to either side. If the air stream strikes any obstruction, i.e. the top edge of the doorway, a structural beam, a door opening device, etc., its efficiency will be greatly reduced. **See Figure 2.**
2. The lower lip of the mounting plate should be no more than 1" above the door opening when the unit is mounted flush to the wall. If the air door must be mounted higher, it must be spaced out from the wall $\frac{3}{8}$ " for every inch the unit is above the door opening. For the best performance, any void between the air door and the wall must be sealed (use foam, plastics or a similar packing). **See Figure 3.**
3. Do not block the air flow to or from the unit since this could cause overheating. **On electrically heated units there should be:**
 - A) a minimum clearance of at least 4" between the side of the unit and any combustible material if the unit is enclosed in the ceiling or a decorative cover.
 - B) a minimum clearance of 8" between the top of the unit and the ceiling in order to service the junction box(es).
 - C) do not install less than six feet (or 1.8 meters) from

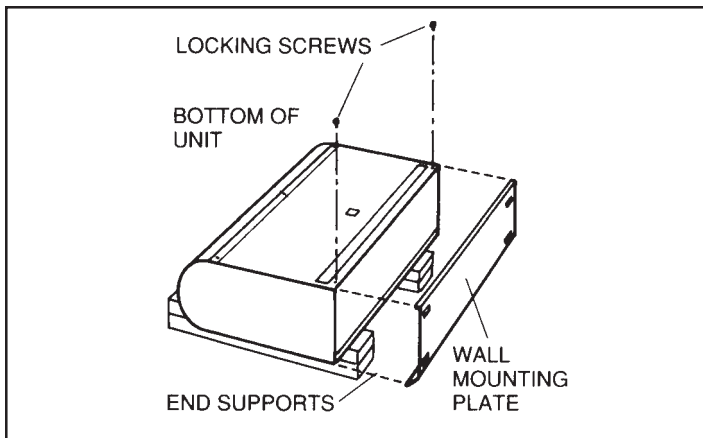

Figure 1

WEIGHT IN POUNDS			
Model	Unheated	Electric	Hot Water/Steam
DP2/MK21036	100	110	120
DP2/MK21042	118	125	140
DP2/MK21048	125	132	155
DP2/MK22048	138	140	197
DP2/MK22060	160	179	210
DP2/MK22072	174	219	222
DP2/MK22084	195	254	227
DP2/MK22096	210	275	235
DP2/MK23096	216	284	240
DP2/MK23108	237	305	248
DP2/MK23120	268	324	270

Table 1

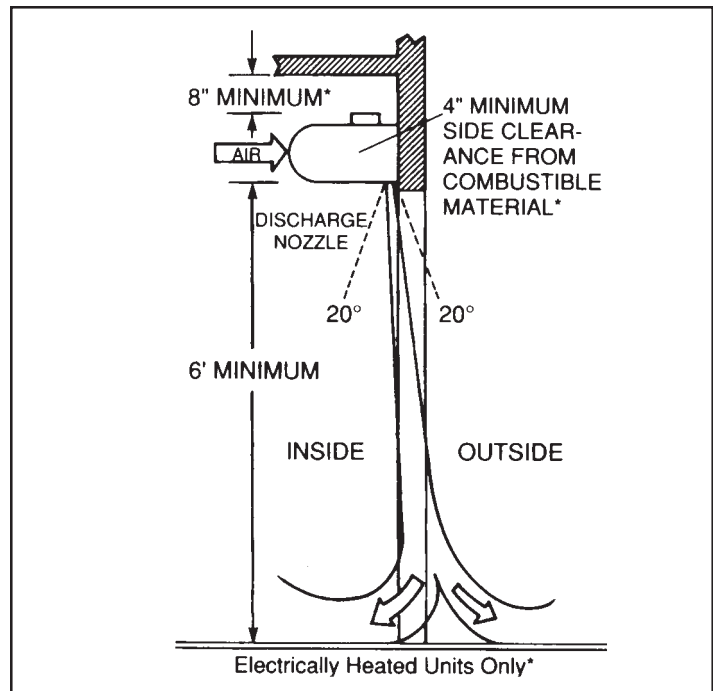

Figure 2

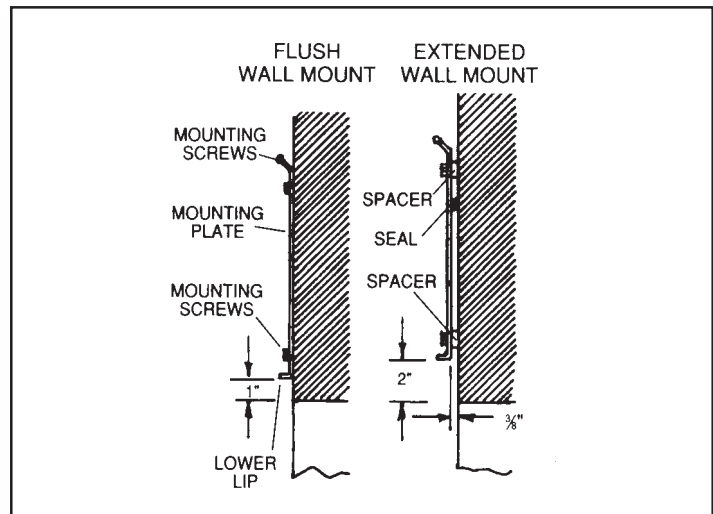

Figure 3

WALL PREPARATION

1. Position and center the mounting plate over the door opening. The mounting plate must be positioned with the 45° lip and the rubber vibration gasket on top. Four (4) slotted mounting holes are provided on the mounting plate. **See Figure 4.**
2. Mark the wall in the center of each mounting plate hole. The wall must provide sufficient support for the air door. The mounting hardware (supplied by others) must be capable of supporting a minimum of three times the net weight of the air door. **See Weight Chart, Table 1.** If the location of the marks on the wall do not provide suitable support, mark and drill additional holes.
3. Drill the four holes as marked on the wall and attach the mounting plate with anchors (if used) and the four mounting screws (provided by others).

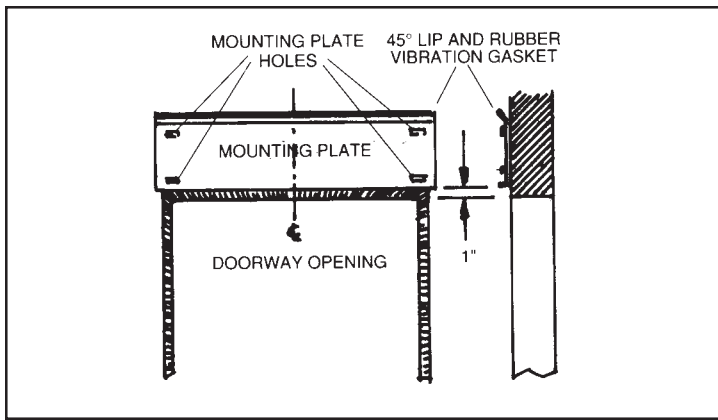

Figure 4

ATTACHING THE AIR DOOR TO THE MOUNTING PLATE

1. Raise the unit over the door (air discharge nozzle facing down) and on to the mounting plate. First, tilt the unit upward matching the top recessed edge of the unit to the top 45° angled lip on the mounting plate. See Figure 5.
2. Lower the unit into place, allowing it to rest on the lower lip of the mounting plate.
3. After the unit is securely attached to the mounting plate, re-install the two (2) locking screws at the bottom corners. See Figure 5.

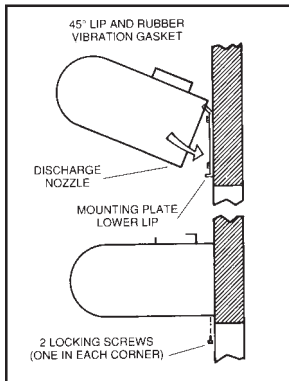

Figure 5

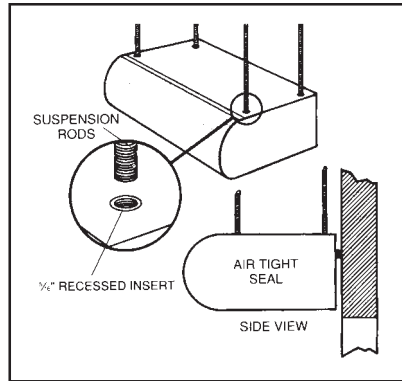

Figure 6

MOTOR DATA				
Model	#Motors @ HP	120 V	208/240 V	460 V*
		1Ø	1Ø	1Ø
		Motor Amps	Motor Amps	Motor Amps
DP2/MK21036	1 @ ½	7.2	4.0	1.3
DP2/MK21042	1 @ ½	7.2	4.0	1.3
DP2/MK21048	1 @ ½	7.2	4.0	1.3
DP2/MK22048	2 @ ½	14.4	8.0	2.6
DP2/MK22060	2 @ ½	14.4	8.0	2.6
DP2/MK22072	2 @ ½	14.4	8.0	2.6
DP2/MK22084	2 @ ½	14.4	8.0	2.6
DP2/MK22096	2 @ ½	14.4	8.0	2.6
DP2/MK23096	3 @ ½	21.6	12.0	3.9
DP2/MK23108	3 @ ½	21.6	12.0	3.9
DP2/MK23120	3 @ ½	21.6	12.0	3.9

*Special 1/3 hp Two Speed Motor

Table 2

INDOOR INSTALLATION: TOP MOUNTING (CEILING SUSPENSION)

For top mounting suspension rods, four (4) factory installed 5/16" threaded inserts are located on the top of the unit. See Figure 6.

1. Install the DIPLOMAT/MARK II Series Air Door so that nothing interferes with the curtain of air when it is deflected 20° to either side. If the air stream strikes any obstruction, i.e. the top edge of the doorway, a structural beam, a door opening device, etc., its efficiency will be greatly reduced. See Figure 2.
2. Follow instructions 2 and 3 under INDOOR INSTALLATION: WALL MOUNTING (on page 1) checking to assure the minimum clearances are met.
3. Attach 5/16" threaded rods, or other suitable hardware to the top mounted threaded inserts.

ELECTRIC HEATER DATA*												
Add total motor amp draw from Table #2 to circuit #1 for unit total amp draw												
MODEL	KW	208V 1Ø		240V 1Ø		208V 3Ø Amp Draw			240V 3Ø Amp Draw		460V 3Ø** Amp Draw Circuit 1	600V 3Ø** Amp Draw Circuit 1
		Circuit 1	Circuit 2	Circuit 1	Circuit 2	Circuit 1	Circuit 2	Circuit 3	Circuit 1	Circuit 2		
DP2/MK21036	9.5	45.7	-	39.6	-	26.4	-	-	22.9	-	11.4	9.5
DP2/MK21042	9.5	45.7	-	39.6	-	26.4	-	-	22.9	-	11.4	9.5
DP2/MK21048	9.5	45.7	-	39.6	-	26.4	-	-	22.9	-	11.4	9.5
DP2/MK22048	12.5	20.0	40.1	17.4	34.7	34.7	-	-	30.1	-	15.0	12.6
DP2/MK22060	16.0	-	-	-	-	44.4	-	-	38.5	-	19.2	16.1
DP2/MK22072	19.0	-	-	-	-	26.4	26.4	-	22.9	22.9	22.9	19.1
DP2/MK22084	19.0	-	-	-	-	26.4	26.4	-	22.9	22.9	22.9	19.1
DP2/MK22096	19.0	-	-	-	-	26.4	26.4	-	22.9	22.9	22.9	19.1
DP2/MK23096	25.0	-	-	-	-	34.7	34.7	-	30.1	30.1	30.1	25.1
DP2/MK23108	28.5	-	-	-	-	26.4	26.4	26.4	22.9	45.7	34.3	28.6
DP2/MK23120	28.5	-	-	-	-	26.4	26.4	26.4	22.9	45.7	34.3	28.6

*Optional kW available. Check wiring diagram supplied with unit for kW and AMP draw if not listed above.

** Separate 120V, 208V or 240V single phase circuit required to operate motors.

Table 3

ELECTRIC WIRING

All electrical wiring should be done in accordance with local codes and regulations.

MAKE SURE THE CORRECT VOLTAGE AS MARKED ON THE UNIT IS USED.

The DIPLOMAT/MARK II air door is internally wired to the junction box(es) on top of the of the unit.

1. Run the proper size cable from the source to the junction box and connect the leads.
2. Wiring diagrams are located inside the junction box. For amp rating, see Tables 2 or 3 and the name plate on the unit.

ELECTRICALLY HEATED MODELS

The heater circuit may be controlled by a remote thermostat, a built-in thermostat or a manual on/off heater switch located on the discharge side of the unit. **See Figure 7.**

1. If a thermostat is used, connect the proper leads located in the junction box to the leads of the thermostat. (See wiring diagram located in the junction box)
2. If a manual heat on/off switch is used, factory wiring is supplied from the heating coil to the unit mounted heat on/off switch.

Overheat protection is provided by thermal cutouts built into the heater coil assembly. (See the wiring diagram located in the junction box.)

STEAM OR HOT WATER HEATED MODELS

Piping should be done in accordance with local codes, regulations and standard practice.

1. Connect the supply & return to the 1" MPT nipples on the heating coil. **See Figure 8.**
2. Temperature controls to be supplied by others.

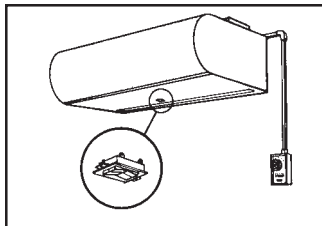

Figure 7

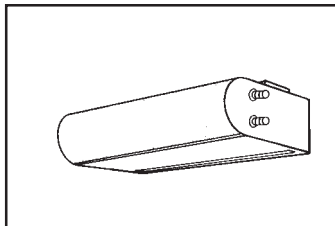

Figure 8

ADJUSTMENTS

AIR FLOW ADJUSTMENTS

1. With the air door operating and the door in its full open position, check to see that nothing is obstructing the air flow at the discharge nozzle.
2. Find the air stream split location. Hold a handkerchief, by its corners, approximately 12" above the floor. Gently move the handkerchief back and forth in the doorway. Make sure the air is being directed to both the inside and the outside. **See Figure 9.** The split location is indicated where the handkerchief is vertical with minimal or no fluttering.
3. The split location should be approximately 3" outside the doorway and 12" above the floor.

If the split location does not conform to the above specifications, the air directional vanes in the outlet nozzle should be adjusted.

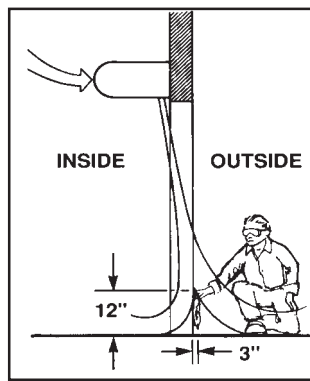

Figure 9

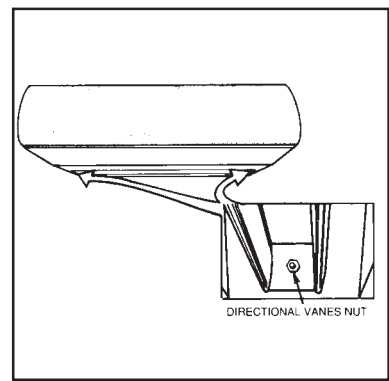

Figure 10

AIR DIRECTIONAL VANES

1. Loosen the two (2) nuts on each end of the outlet nozzle. Adjust the air directional vanes so the air flow split is in the proper location. **See Figure 10.**
2. Retighten the two screws after air directional adjustment is complete.

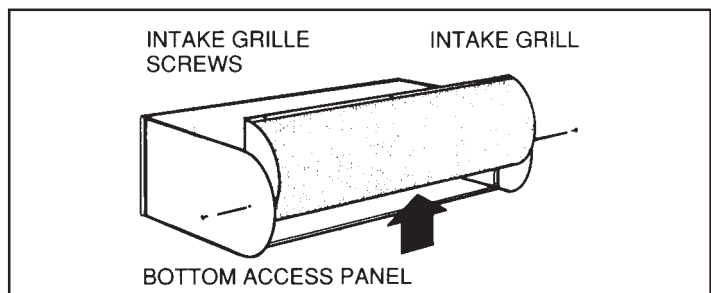

Figure 11

MAINTENANCE AND CLEANING

WARNING: Before servicing or cleaning the unit, switch the power off at the service panel and lock the service panel to prevent the power from being switched on accidentally.

To keep your air door operating at peak efficiency, the blower wheels, housings, motor(s) and intake grille must be kept free of dust and debris. Buildup of dust on the blower wheels can cause vibration, noise and excessive wear on the motor bearings. The frequency of cleaning will depend on the environment where the unit is operating.

Dirty, dusty or greasy environments could require a cleaning schedule of once every two weeks. If the environment is not that dirty, the unit(s) should be scheduled for cleaning a minimum of once every (3) months. Contact your maintenance department to schedule your unit for periodic cleaning when the air door is installed.

To access the interior of the unit:

1. Remove the intake grille by removing the locking screw on each end of the unit. Lift the intake grille up and then towards you.

2. Remove the bottom access panel. Remove Phillips head screws on the bottom of the unit. Vacuum and scrape (if necessary) to remove the build-up of dirt and debris. The motor(s) are permanently lubricated and require no additional lubrication. Re-install the cover and intake grille.

IMPORTANT: Reconnect the power source after cleaning.

Use this unit only in the manner intended by the manufacturer. If you have any questions, contact the manufacturer.

TROUBLESHOOTING

SYMPTOMS	CAUSE	REMEDY
NO AIR	<ul style="list-style-type: none"> Power supply line open (no power) Fuse blown/circuit breaker tripped Motor overload tripped Failed switch 	<ul style="list-style-type: none"> Check power source, check method of control in ON position Replace fuse(s)/reset breaker Internally protected motor - should reset automatically after cool-down, if not, replace motor. Replace switch
	MOTOR RUNNING/FANS ARE NOT ROTATING	
	<ul style="list-style-type: none"> Broken or damaged flexible hub Shaft rotating inside fan 	<ul style="list-style-type: none"> Replace fan sleeve/reengage coupling Tighten set screws/tighten fan on shaft
MINIMUM AIR	ELECTRICAL CONTROLS NOT FUNCTIONING WHEN DOOR IS OPEN	
	<ul style="list-style-type: none"> Selector switch is in off position Door limit switch not operating 	<ul style="list-style-type: none"> Turn switch to "ON" position Repair or replace limit switch
	<ul style="list-style-type: none"> Air directional discharge vanes mis-adjusted Inadequate intake clearance Blower motor operates below speed Fan rubbing against housing Fan wheels clogged with dirt Fan in backwards 	<ul style="list-style-type: none"> Adjust vanes to proper position, see instructions Move air curtain or remove obstruction Provide adequate space for air curtain Improper voltage Free fan from housing Clean and vacuum fan wheels Check fans for blade curve toward discharge
NO SPEED ADJUSTMENT	<ul style="list-style-type: none"> Speed sensor not detecting trigger rotation 	<ul style="list-style-type: none"> Adjust gap between sensor & trigger/replace sensor
AIR IS NOT HITTING FLOOR	<ul style="list-style-type: none"> Air stream too weak Air steam hits obstruction Negative pressure 	<ul style="list-style-type: none"> Adjust nozzle to proper position, adjust motor speed; see installation instructions Remove obstruction or reposition air curtain (move out 3/8" for every 1" up from the door) Relieve negative pressure by providing makeup air
UNEVEN AIR	<ul style="list-style-type: none"> Shaft rotating inside fan One motor not operating 	<ul style="list-style-type: none"> Tighten set screws Repair or replace motor
EXCESSIVE AIR MOVEMENT AT DOORWAY	<ul style="list-style-type: none"> Nozzle not angled out far enough Unit too powerful Air movement too cold Pushing air outside building <p>SEE AIR IS NOT HITTING FLOOR SYMPTOMS</p>	<ul style="list-style-type: none"> Adjust nozzle angle to outside Adjust motor speed Add auxiliary heat to overcome wind chill factor Adjust discharge angle back into building, adjust motor speed
ELECTRICALLY HEATED MODELS		
NO HEAT	<ul style="list-style-type: none"> Switch turned to "ON" position Thermostat not set properly Coils burned out due to lack of air Automatic reset thermal cutout failed in open position Manual reset thermal cutout tripped (if supplied) Speed sensor not detecting trigger rotation Without speed adjustment, failed speed sensor 	<ul style="list-style-type: none"> Replace switch or check wiring Change thermostat setting Correct airflow problem; replace coils Replace automatic thermal cutout Reset manual thermal cutout Adjust gap between sensor and trigger Replace speed sensor
MINIMAL HEAT	<ul style="list-style-type: none"> Thermostat in wrong location - thermostat too close to discharge Improper voltage Thermostat not set properly Speed sensor not detecting trigger rotation 	<ul style="list-style-type: none"> Move thermostat away from air stream Supply proper voltage Change temperature setting Adjust gap between sensor & trigger/replace sensor
EXCESSIVE HEAT	<ul style="list-style-type: none"> Incorrect speed range Thermostat in wrong location Thermostat not set properly Insufficient air over coil Improper voltage 	<ul style="list-style-type: none"> Set dip switch to electric heated speed range Move the thermostat closer to air stream Change temperature setting Remove restriction on intake Supply proper voltage
STEAM/HOT WATER HEATED UNITS		
EXCESSIVE HEAT	<ul style="list-style-type: none"> Too high steam/hot water pressure Inadequate air flow, fins plugged up, dirty coils 	<ul style="list-style-type: none"> Reduce steam pressure/hot water flow Clean intake and coils
MINIMAL HEAT	<ul style="list-style-type: none"> Insufficient removal of condensation (steam) Not enough steam pressure/water temperature too low Intake air below design temperature 	<ul style="list-style-type: none"> Increase trap size Raise pressure for steam/increase water flow Increase steam pressure/increase water flow

WARRANTY

Berner International warrants all new equipment to be free of defects in workmanship and material for a period of five years (5 years) on unheated models and two years (2 years) on heated models from the original date of shipment, provided the equipment has been properly cared for, installed and operated in accordance with the limits specified on the nameplate and The Company's instructions.

The Company will correct by repair or replacement, at its option and expense, any proven defects in said apparatus, subject to the above conditions, provided that immediate written notice of such defects is given to the Company. The warranty does not include any labor incurred for the removal or installation of defective part(s). The Company reserves the right to inspect, or have inspected by a qualified representative, any apparatus at the place of installation before authorizing repair or replacement. Repair or replacement will be made F.O.B. factory with any applicable transportation charges to be borne by the customer. Merchandise not of the Company's manufacture supplied in piece, or in component assemblies, is not covered by the above warranty, but the Company will give the customer the benefit of any adjustment as made with the Manufacturer.

This warranty is void if the apparatus has been tampered with in any way or shows evidence of misuse.

The Company will not assume any expense or liability for repairs made outside its factory without proper written consent from its service manager, nor for any transportation charges on apparatus returned to the factory without written authorization by the Company.

Nothing in the above warranty provisions, however, shall impose any liability or obligation of any type, nature or description upon Berner International if Berner has not received payment in full for the apparatus in question.

THERE ARE NO WARRANTIES WHICH EXTEND BEYOND THE DESCRIPTION ON THE FACE HEREOF INCLUDING THE IMPLIED WARRANTY OF MERCHANTABILITY AND FITNESS FOR A PARTICULAR PURPOSE.

LIMITATION OF DAMAGES

Notwithstanding anything to the contrary above, customer's exclusive remedy for any and all losses or damages resulting from the sale of The Company's equipment under this agreement, including but not limited to, any allegations of breach of warranty, breach of contract, negligence or strict liability, shall be limited, at The Company's option, to either the return of the purchase price or the replacement of the particular equipment for which a claim is made and proved. In no event shall The Company be liable for any special, consequential, incidental or indirect losses or damages from the sale of The Company's equipment under this agreement.

Serial Number _____ Model Number _____ Date Purchased _____



Berner International Corporation

New Castle, PA

724-658-3551

1-800-245-4455

www.berner.com